

GOVERNMENT OF TRIPURA
OFFICE OF THE BLOCK DEVELOPMENT OFFICER
DASDA RD. BLOCK, TRIPURA (N).

No.1862-74/F.3(9)/BDO/DSD/TENDER/2018-19/

Dated: 02nd November, 2018.

NOTICE INVITING TENDER

On behalf of the Governor of Tripura the undersigned invites sealed tender of rate in the plain paper for Procurement of joint Benches and Tables at Anandabazar HS School under Dasda RD Block North Tripura under BEUP fund sanctioned during the financial year 2017-18. The tenderer should also submit required documents and Earnest Money of Rs.5,000/- (Rupees Five thousand) only to be submitted in the shape of Demand draft (DD) in favour of undersigned drawn on any Bank of India payable at Kanchanpur along with the tender.

The tender box will be kept open for dropping of tender by the intending tenderer in the office chamber of the undersigned from 05/11/2018 to 19/11/2018 and time from 10:00 AM to 3:00 PM except Government holiday and the box will be Opened on 19/11/2018 at 3:30 PM if possible. If the last date of tender dropping/opening tender becomes paralyzed due to any unforeseen reason the next Government working day will be the last date of dropping of tender and opening of tender box or to be notified accordingly.

The interested tenderer should quote the rates as per prescribed format given below along with copy of GST Registration Certificate, Shop/Store/Registration Certificate, Trade License, Adhaar Card, Bank Passbook, PRTC, PAN card as evidence of valid bidder and permanent resident of Tripura. The tenderer should quote the rate against per unit Joint Bench & Table including GST/IT etc. and carrying cost upto Anandabazar HS School. Any incomplete Tender will summarily be rejected. Specification of Joint bench & Table are given below:-

SL. No.	Description of articles	Per Unit Quoted Rate	Place of Delivery	Remarks
1	2	3	4	
1	Joint Bench Double Size having desk (3 feet * 16 inch * 2½ feet) and bench of (3 feet * 12 inch * 18 inch) made of Teak/Karai wood with complete polishing and Varnishing.		As per supply order.	
2	Tables Size 30 " width , 40" length & 28" Height (made of Teak/Karai wood with complete polishing and Varnishing).			

Cont page-2

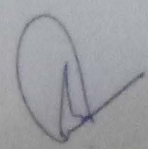

Terms & Condition:

1. The Joint Benches and Tables should be recently manufactured as per desired specification.
2. Supply shall be completed within 30(thirty) days at the Anandabazar HS School from the date of receipt of supply order. Supplier will arrange test check all the supplied equipments in front of the undersigned and all the items will be accepted if each item of supplied equipments is found in order. If supplier fails to supply required materials within 30(thirty) days, the earnest money as deposited in shape of Demand Draft (DD) will be forfeited.
3. Any unstipulated material supplied will not be accepted and if any unstipulated materials are found, it must be replaced by the supplier at own risk and own cost.
4. Warranty: 12(twelve) months from the date of supply of Joint Benches and Tables.
5. The undersigned reserves the right to cancel part or whole affairs without assigning any reason.
6. Bill will be raised in triplicate by obtaining certificate from the respective Section-in-Charge for quality checking.
7. Copy enclosed of Diagram.

(Bipul Das) TCS

Block Development Officer
Dasda R.D.Block,Tripura(N).

Copy to:

1. The District Magistrate & Collector, North Tripura, Dharmanagar for kind information.
2. The Director, ICAT, Agartala, West Tripura for kind information.
3. The Sub-Divisional Magistrate, Kanchanpur, North Tripura for kind information.
4. The Block Development Officer, Jampui Hill /Damcherra /Panisagar/ Kadamtala/Jubaraj Nagar/Kalacherra/Laljuri R.D.Block for information with a request to display in their Notice Board.
5. The District Informatics Assistant, NIC attached to the office of the DM & Collector, North Tripura District, Dharmanagar for information and with a request to float the Notice Inviting Tender www.northtripura.nic.in@gmail.com and [www. Tenders.gov.in](http://www.Tenders.gov.in).
6. E-mail to portal.tripura@gmail.com with a request to arrange for floating the Notice inviting Tender in www.tripura.gov.in
7. Notice Board of this Office.

(Bipul Das) TCS

Block Development Officer
Dasda R.D.Block,Tripura(N).

JOINT BENCH Diagram

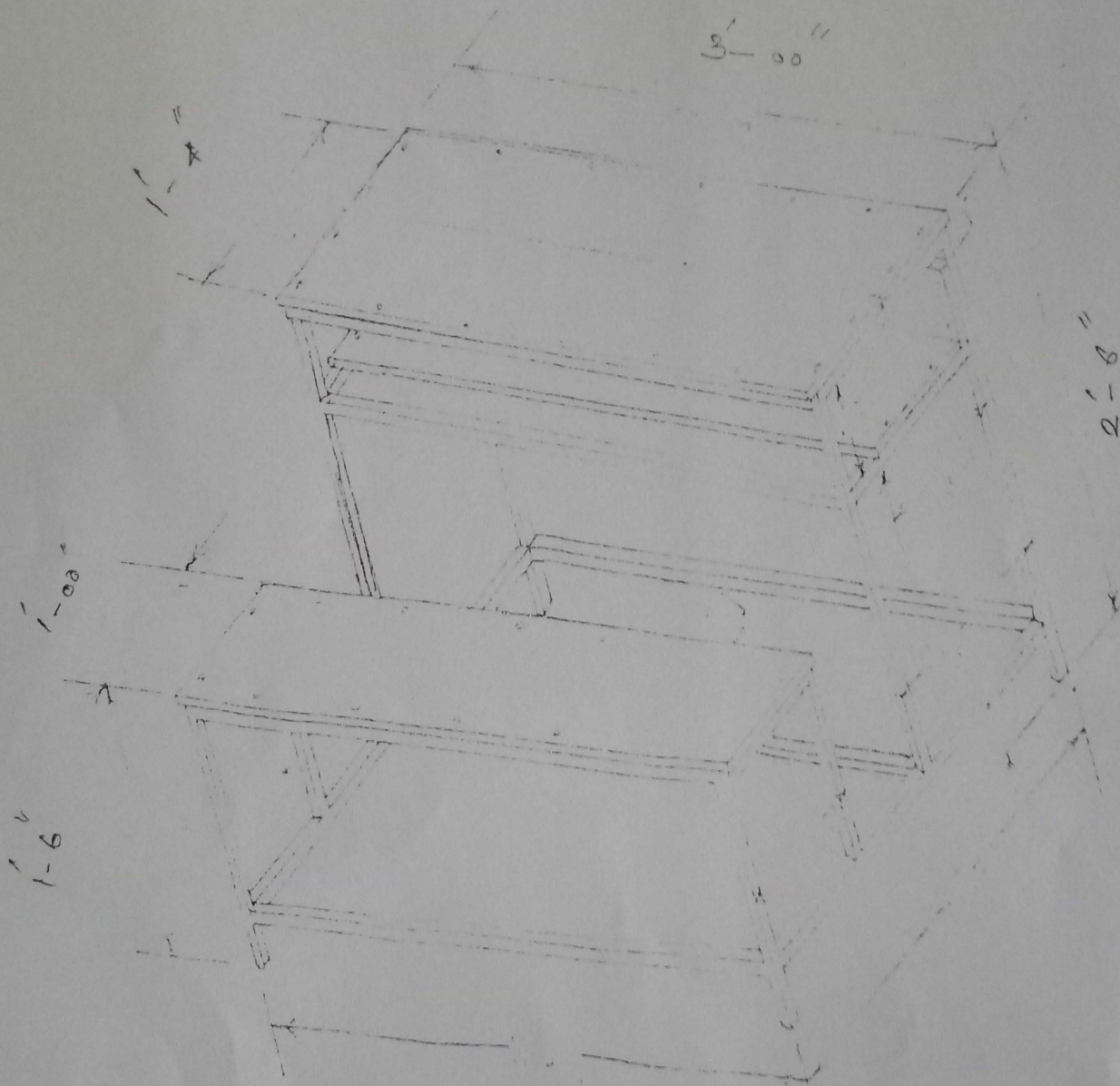

The size and thickness of woods are given below:

- (a) post - 2" x 2"
- (b) Runner - 3' x 1 1/2"
- (c) Bench shuttering - 1"



02/11/18
Block Development Officer
Dasda R.D. Block Tripura (N)

TABLE DIAGRAM.

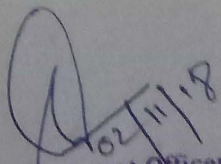
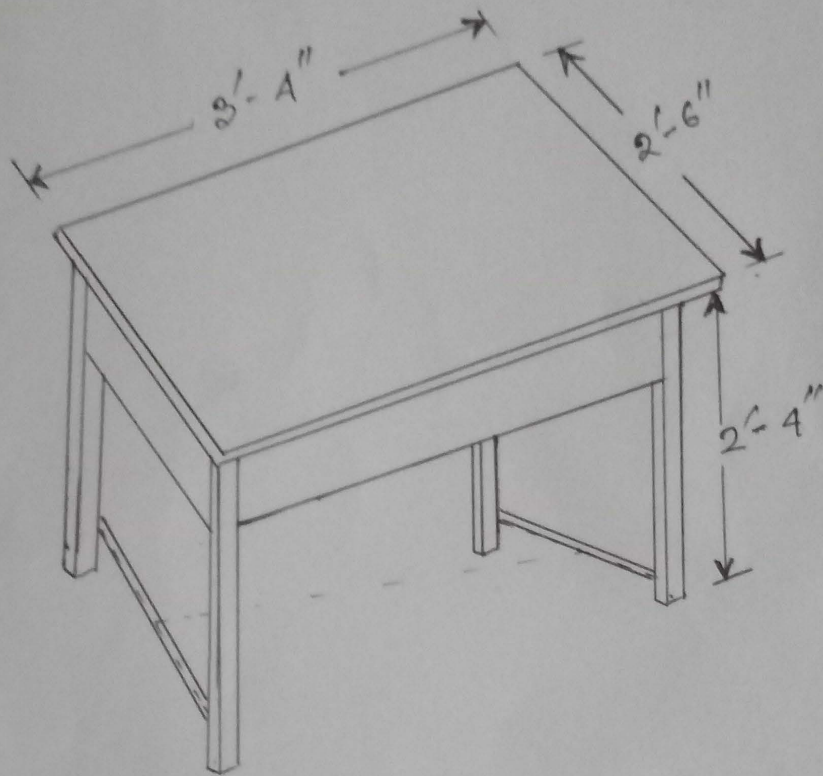

The Size and Thickness of woods are given below :-

(a) Post - $2'' \times 2''$ (b) Runners :- (i) $3'-4'' \times 1\frac{1}{2}''$ (ii) $2'-6'' \times 1\frac{1}{2}''$

(c) Table shuttering. - $1''$

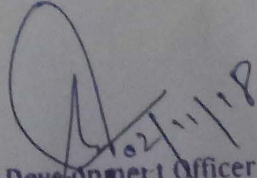
21/11/18
Block Development Officer
Dasda R.D. Block Tripura (N)